

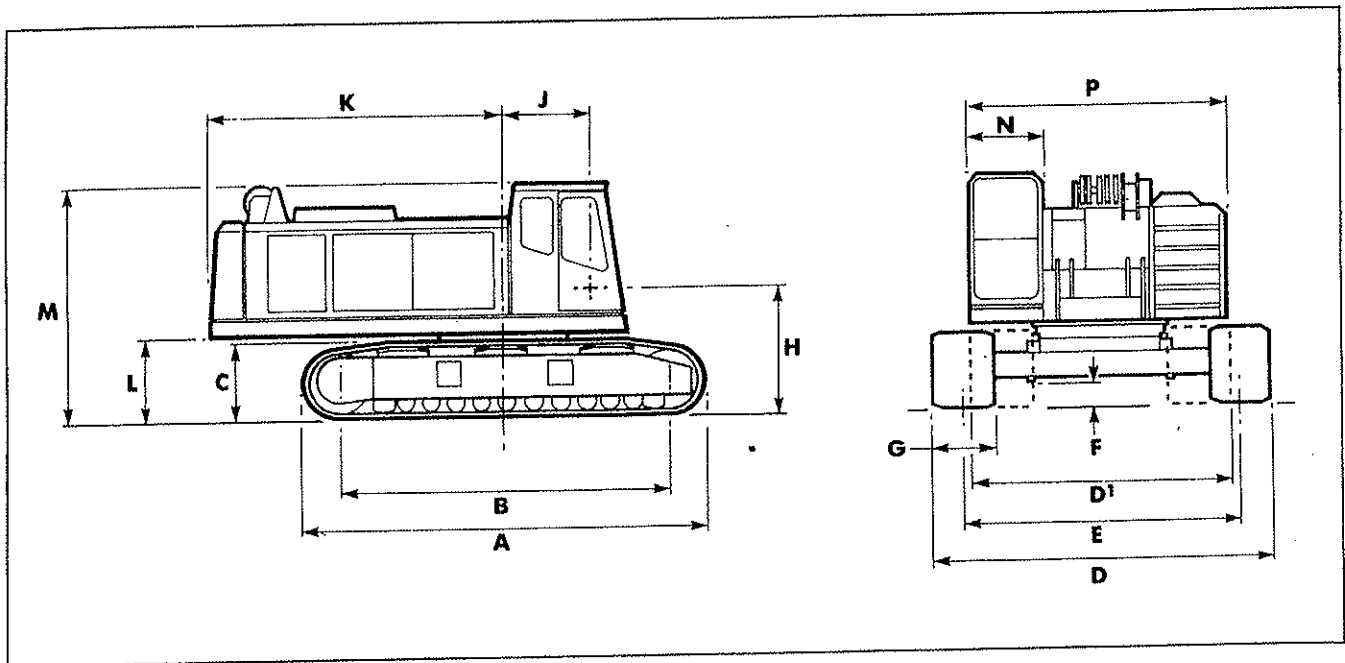

# HC50 DATA



## DIMENSIONS

	metres
<b>A</b> Overall length of crawler units	5.50
<b>B</b> Distance, centre to centre of tumblers	4.50
<b>C</b> Height of crawler units	1.05
<b>D</b> Overall width of crawlers: Extended – in working condition	4.59
<b>D'</b> Retracted – in travelling condition	3.50
<b>E</b> Centre to centre of crawler units in working condition	3.74
<b>F</b> Ground clearance	450mm
<b>G</b> Crawler shoe width	850mm

	metres
<b>H</b> Height of boom foot	1.75
<b>J</b> Distance centre line rotation to boom foot	1.16
<b>K</b> Tailradius to rear of counterweight	4.14
<b>L</b> Ground clearance under counterweight	1.15
<b>M</b> Overall height of "A" frame sheave, and operators cab in working condition	3.20
<b>N</b> Width of Operators Module	950mm
<b>P</b> Overall width over machinery cab	3.44

## Offset Head Boom Radius Diagram

Users are referred to British Standards Code of Practice (CP 3010:1972) "Safe Use of Cranes", which gives guidance for the safe application and operation of mobile cranes.

The Gross Working Loads listed in the duty tables are to be used under the following conditions:

### Warning

Operating this equipment in excess of the rated loads shown in the following capacity charts or contrary to our Instruction Manual will result in unsafe conditions, damage to the machine and invalidate the warranty.

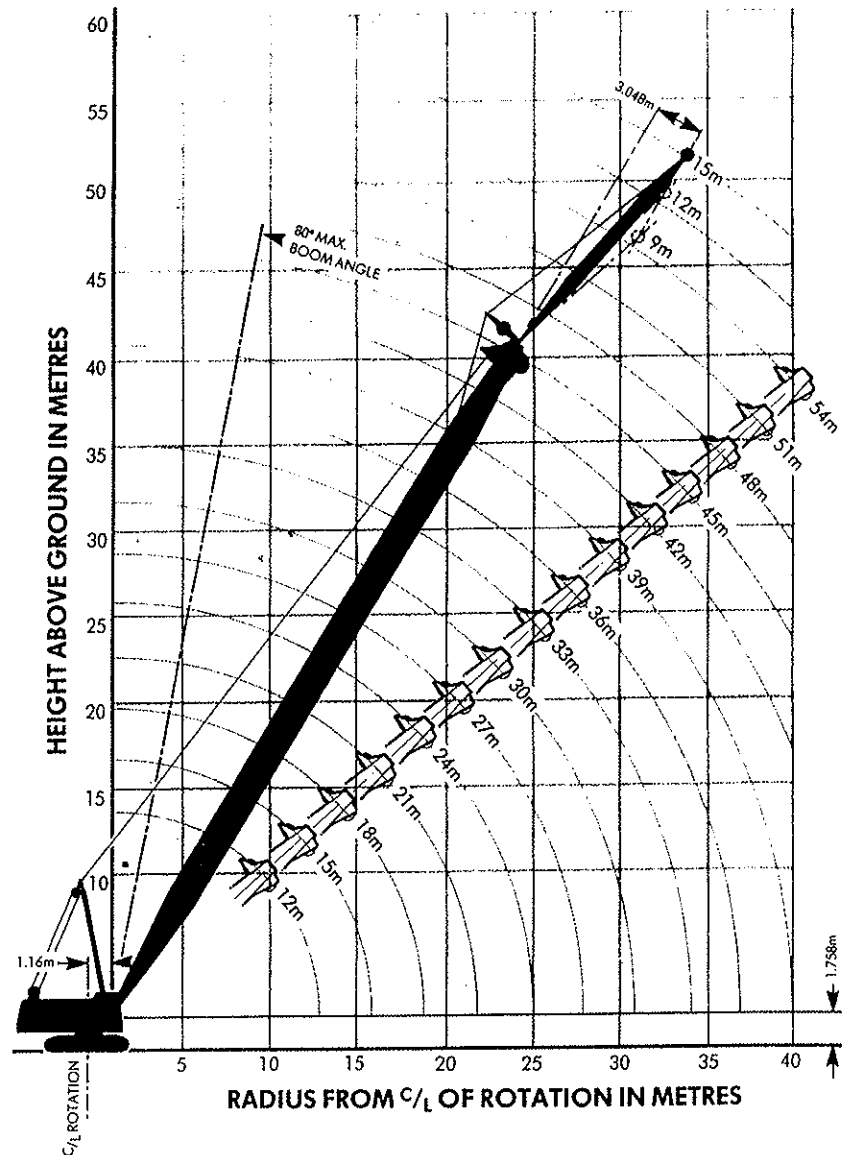

I.S.O. 4305:1981, BS 1757:1986, D.I.N. 15019 pt. 2, Crane Ratings

Capacities in accordance with the requirements of Clause 11, Stability of BS 1757:1986 with wind forces to Table 2(a) and 3(a) of BS 2573, Part 1:1977 and also meet the Determination of Stability of International Standard ISO 4305, and Stability of Mobile Cranes DIN 15019 part 2.

Loads must be freely suspended and the machine standing on firm ground, level to less than 1 in 100.

Loads shown are gross and the weights of all hook blocks, slings, etc., must be deducted to determine nett working loads.

### 75% Crane Ratings

Rated loads do not exceed 75% of the tipping loads but in certain instances, are further governed by structural limitations.

Ratings are based on freely suspended loads and make no allowance for such factors as wind effects, ground conditions, out of level, operating speeds or any other conditions that could be detrimental to the safe operation of this equipment.

Loads shown are gross and the weights of all hook blocks, slings, etc., must be deducted to determine nett working loads.

### Main Boom Loads

Main boom with off-set head - maximum capacity 50,000 kg., maximum length 54.0m.

When a fly jib is fitted the effective weight of all hook blocks, tackle, etc., must be deducted when calculating nett working loads. The main boom loads must be further reduced by the following, to allow for the weight of the fly jib:

9m Fly jib - reduce by 916 kg

12m Fly jib - reduce by 1098 kg

15m Fly jib - reduce by 1270 kg

Maximum length of main boom, when 9m and 12m fly jib are fitted - 45.0m.

Maximum length of main boom, when 15m fly jib is fitted - 42.0m.

### Fly Jib Loads

Maximum fly jib gross loads:

9m Fly jib 6300 kg

12m Fly jib 5490 kg

15m Fly jib 4470 kg

Effective weight of all suspended hook blocks, slings and tackle must be deducted when calculating nett working loads.

### Fly jib offset

With the standard pendant ropes supplied for each fly jib the offset of the fly jib head from the centre line of the main boom is 3.048m, regardless of fly jib length.

This offset dimension must be maintained at all times.

### Liftcrane Hoist Rope Loads

24mm Rope (Front Drum)

No. of Parts of Rope	Maximum Lifting Capacity kg
1	7190
2	14240
3	21140
4	27920
5	34560
6	41080
7	47460
8	50000

20mm Rope (Rear Drum)

No. of Parts of Rope	Maximum Lifting Capacity kg
1	6300

The above capacities are derived from rope factors of safety to BS 1757:1986; also in accordance with P.C.S.A. Standard No. 1, and maximum pulls from hoist drums.

# HC50 DATA

## LIFTING CAPACITIES OFFSET HEAD BOOM MAIN BOOM (with maximum counterweight)

METRIC

Boom length	Radius	Boom angle	GROSS WORKING LOAD	
			BS 1757:1986	75% Rating
m	m	degrees	* kg *	kg
12.0	3.6	80	50000	50000
	4.0	78	50000	47300
	5.0	73	33700	31700
	6.0	68	25200	23700
	7.0	63	20070	18900
	8.0	57	16600	15700
	9.0	51	14140	13300
	10.0	44	12280	11600
15.0	4.1	80	47900	45000
	5.0	77	33600	31600
	6.0	73	25100	23600
	7.0	68	20000	18800
	8.0	64	16500	15600
	9.0	60	14000	13300
	10.0	55	12200	11500
	12.0	45	9600	9100
18.0	4.6	80	38700	36400
	5.0	79	33500	31500
	6.0	76	25000	23500
	7.0	72	19900	18700
	8.0	69	16400	15500
	9.0	65	13900	13200
	10.0	62	12100	11400
	12.0	54	9500	9000
21.0	5.2	80	32300	30400
	6.0	78	24900	23500
	7.0	75	19800	18600
	8.0	72	16300	15400
	9.0	69	13800	13100
	10.0	66	12000	11300
	12.0	60	9400	8900
	14.0	53	7600	7200
24.0	5.7	80	27600	26000
	6.0	79	24800	23400
	7.0	77	19700	18600
	8.0	74	16200	15300
	9.0	72	13700	13000
	10.0	69	11900	11300
	12.0	64	9300	8800
	14.0	59	7500	7200
27.0	6.2	80	24400	23000
	7.0	78	19600	18500
	8.0	76	16100	15200
	9.0	74	13600	12900
	10.0	72	11800	11200
	12.0	67	9200	8700
	14.0	62	7400	7100
	16.0	57	6200	5900
39.0	6.2	80	24400	23000
	7.0	78	19600	18500
	8.0	76	16100	15200
	9.0	74	13600	12900
	10.0	72	11800	11200
	12.0	67	9200	8700
	14.0	62	7400	7100
	16.0	57	6200	5900

Boom length	Radius	Boom angle	GROSS WORKING LOAD	
			BS 1757:1986	75% Rating
m	m	degrees	kg	kg
30.0	6.7	80	20800	19600
	7.0	79	19500	18400
	8.0	78	16000	15100
	9.0	76	13500	12800
	10.0	74	11700	11100
	12.0	70	9100	8600
	14.0	65	7300	7000
	16.0	61	6100	5800
	18.0	57	5100	4900
	20.0	52	4400	4200
	22.0	47	3800	3700
	24.0	41	3300	3200
	26.0	35	2900	2900
	28.0	27	2600	2600
33.0	7.2	80	18600	17600
	8.0	79	15900	15100
	9.0	77	13400	12700
	10.0	75	11600	11000
	12.0	71	9000	8500
	14.0	68	7200	6900
	16.0	64	6000	5700
	18.0	60	5000	4900
	20.0	56	4300	4200
	22.0	51	3700	3600
	24.0	47	3200	3200
	26.0	42	2800	2800
	28.0	36	2500	2500
	30.0	30	2200	2200
36.0	8.0	80	15800	15000
	9.0	78	13300	12700
	10.0	76	11500	10900
	12.0	73	8900	8500
	14.0	70	7100	6800
	16.0	66	5900	5600
	18.0	63	4900	4800
	20.0	59	4200	4100
	22.0	55	3600	3500
	24.0	51	3100	3100
	26.0	47	2700	2700
	28.0	42	2400	2400
	30.0	37	2100	2100
	32.0	32	1800	1900
34.0	25	1700	1800	
39.0	8.3	80	14900	14100
	9.0	79	13200	12600
	10.0	77	11400	10800
	12.0	74	8800	8400
	14.0	71	7000	6700
	16.0	68	5800	5600
	18.0	65	4800	4700
	20.0	62	4100	4000
	22.0	58	3500	3400
	24.0	55	3000	3000
	26.0	51	2600	2600
	28.0	47	2300	2300
	30.0	43	2000	2000
	32.0	38	1700	1800
34.0	33	1500	1600	
36.0	27	1300	1400	

# HC50 DATA

## LIFTING CAPACITIES OFFSET HEAD BOOM MAIN BOOM (with maximum counterweight)

METRIC

Boom length	Radius	Boom angle	GROSS WORKING LOAD	
			BS 1757:1986	75% Rating
m	m	degrees	kg	kg
42.0	8.8	80	13000	12900
	9.0	80	12900	12500
	10.0	78	11300	10800
	12.0	76	8700	8300
	14.0	73	6900	6700
	16.0	70	5700	5500
	18.0	67	4700	4600
	20.0	64	4000	3900
	22.0	61	3400	3400
	24.0	58	2900	2900
	26.0	54	2500	2500
	28.0	51	2200	2200
	30.0	47	1900	1900
	32.0	43	1600	1700
	34.0	39	1400	1500
	36.0	34	1200	1300
	38.0	29	1000	1100
40.0	23	900	1000	
45.0	9.3	80	11300	11300
	10.0	79	11100	10700
	12.0	77	8600	8200
	14.0	74	6800	6600
	16.0	71	5600	5400
	18.0	68	4600	4500
	20.0	66	3900	3800
	22.0	63	3300	3300
	24.0	60	2800	2800
	26.0	57	2400	2400
	28.0	54	2100	2100
	30.0	51	1800	1900
	32.0	47	1500	1600
	34.0	44	1300	1400
	36.0	40	1100	1200
	38.0	35	1000	1100
	40.0	31	800	900
48.0	10.0	80	9800	9800
	12.0	77	8500	8100
	14.0	75	6700	6500
	16.0	72	5500	5300
	18.0	70	4500	4400
	20.0	67	3800	3700
	22.0	65	3200	3200
	24.0	62	2700	2700
	26.0	59	2300	2300
	28.0	56	2000	2000
	30.0	53	1700	1800
	32.0	50	1400	1500
	34.0	47	1200	1300
	36.0	44	1000	1100
	38.0	40	800	1000
	40.0	36	700	800
	42.0	32	500	700

Boom length	Radius	Boom angle	GROSS WORKING LOAD	
			BS 1757:1986	75% Rating
m	m	degrees	kg	kg
51.0	10.4	80	8600	8600
	12.0	78	8200	8000
	14.0	76	6600	6400
	16.0	73	5400	5200
	18.0	71	4400	4300
	20.0	69	3700	3600
	22.0	66	3100	3100
	24.0	64	2600	2600
	26.0	61	2200	2300
	28.0	59	1900	2000
	30.0	56	1600	1700
	32.0	53	1300	1400
	34.0	50	1100	1200
	36.0	47	900	1000
	38.0	44	700	900
	40.0	41	600	700
	42.0	37	500	600
54.0	11.0	80	7500	7500
	12.0	79	7300	7300
	14.0	77	6500	6300
	16.0	74	5300	5100
	18.0	72	4300	4200
	20.0	70	3600	3600
	22.0	68	3000	3000
	24.0	65	2500	2600
	26.0	63	2100	2200
	28.0	61	1800	1900
	30.0	58	1500	1600
	32.0	56	1200	1400
	34.0	53	1000	1200
	36.0	50	800	1000
	38.0	47	600	800
	40.0	44	500	700

## POWER UNIT

Manufacturer	Caterpillar
Model	3306-DIT
Type	4-cycle diesel engine
Number of cylinders	6
Bore (mm)	121

Stroke (mm)	152
Output power – B.H.P. (kW)	201 (150)
Speed (rpm)	1800
Fuel tank capacity – litres (galls)	400 (88)
Electrical system (volts)	24

## WINCH DRUM DATA Rope Pulls and Speeds

### LIFTCRANE

Main hoist drum P.C.D. (mm)	514
Drum length (mm)	585
Main hoist rope dia. (mm)	24
Max. rope capacity (M)	150
1st layer capacity (M)	34
Effective rope pull (kg)	15000
Max. rope pull (kg)	17740
Main/aux. rope speed (hoist/lower) (M/min)	0 – 126
Auxiliary hoist drum P.C.D. (mm)	514
Drum length (mm)	585
Aux. hoist rope dia. (mm)	20
Max. rope capacity (M)	190
1st layer capacity (M)	41

### DRAGLINE

Drag/hoist drum P.C.D. (mm)	590
Drum length (mm)	585
Drag/hoist rope dia. (mm)	24
1st layer capacity (M)	39
Rope pull (kg)	15400
Rope speed (M/min)	0 – 72













### GRABCRANE

Closing/holding drum P.C.D. (mm)	590
Drum length (mm)	585
Closing/holding rope dia. (mm)	24
Max. rope capacity (M)	85
1st layer capacity (M)	39
Effective rope pull (kg)	15000
Rope speed (M/Min)	0 – 48

### BOOM SUSPENSION

Type	Mast – Pendant
Boom hoist drum P.C.D. (mm)	385
Boom hoist rope dia. (mm)	16
Pendant rope dia. (mm)	26
Swing speed (rpm)	0 – 3
Travel speed (kM/hr)	0 - 1.52

## WEIGHTS of major components

	kg.									
<b>BASE MACHINE</b> (without counterweight) 	35300									
<b>UPPER UNIT</b> (without counterweight) 	13750									
<b>CRAWLER UNITS</b> 	8100									
<b>CARBODY</b> 	5400									
<b>BASIC BOOM (12M)</b> 	1680									
<b>BOOM INSERTS</b> <table style="display: inline-table; vertical-align: middle;"> <tr> <td></td> <td>3M</td> </tr> <tr> <td></td> <td>6M</td> </tr> <tr> <td></td> <td>9M</td> </tr> </table>		3M		6M		9M	<table style="display: inline-table; vertical-align: middle;"> <tr> <td>232</td> </tr> <tr> <td>412</td> </tr> <tr> <td>582</td> </tr> </table>	232	412	582
	3M									
	6M									
	9M									
232										
412										
582										
<b>FLY JIBS</b> <table style="display: inline-table; vertical-align: middle;"> <tr> <td></td> <td>9M</td> </tr> <tr> <td></td> <td>12M</td> </tr> <tr> <td></td> <td>15M</td> </tr> </table>		9M		12M		15M	<table style="display: inline-table; vertical-align: middle;"> <tr> <td>610</td> </tr> <tr> <td>750</td> </tr> <tr> <td>890</td> </tr> </table>	610	750	890
	9M									
	12M									
	15M									
610										
750										
890										
<b>COUNTERWEIGHT</b> 	9780									